

# DCS365N Base Assembly 18V MITER SAW 1

140——141

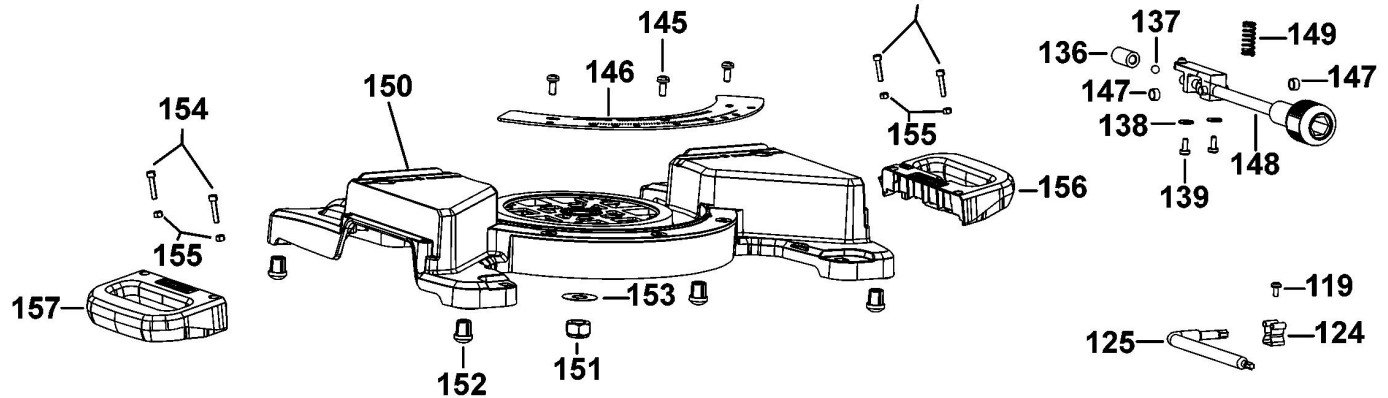

# DCS365N 18V MITER SAW 1

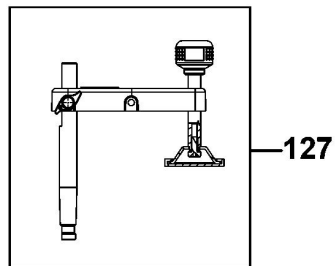
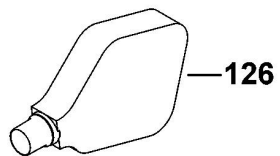
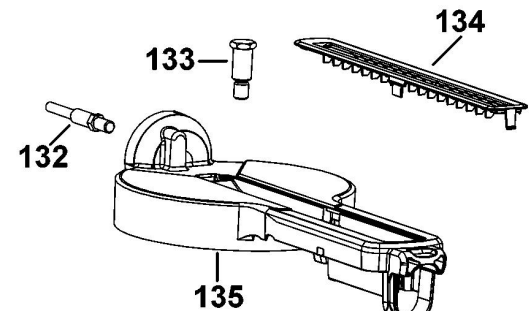
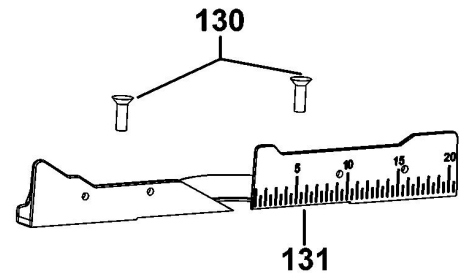
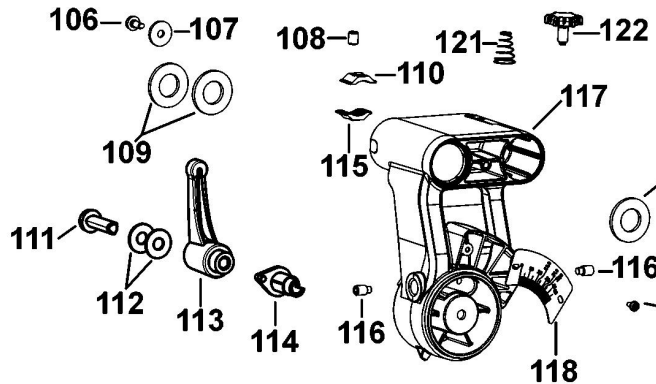
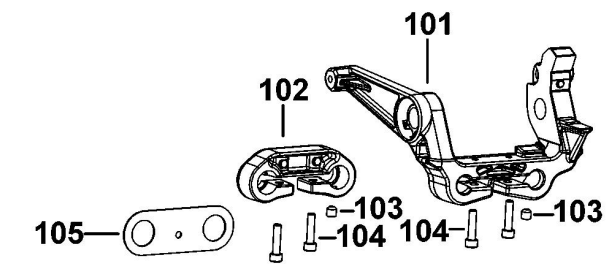
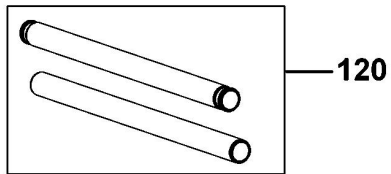
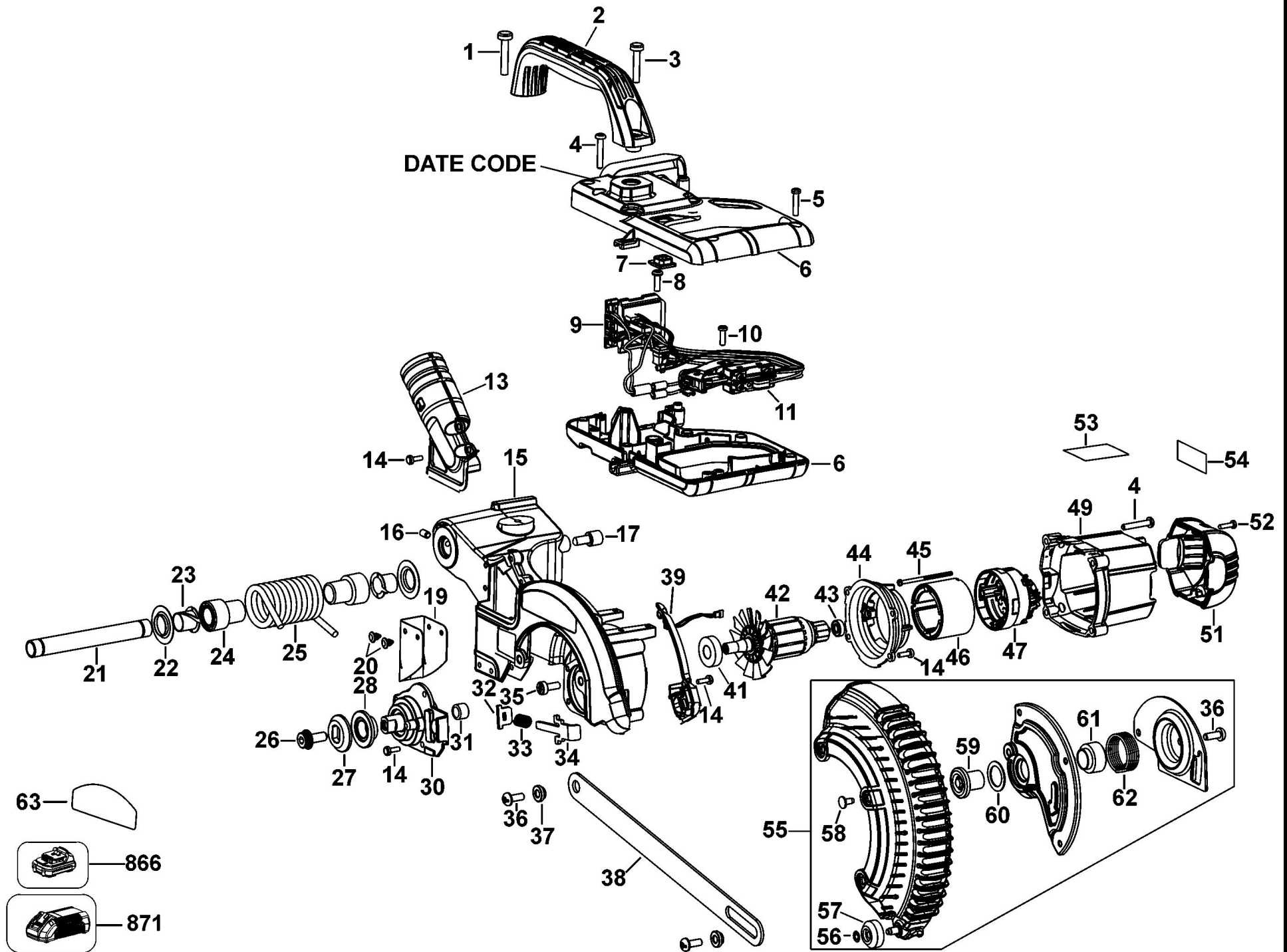

## Parts List DCS365N 18V MITER SAW 1

Item	Part Number	Qty	Part Description	General Description	Other Info	Repair Inst	Markets
1	330045-26	1	SCREW			Yes	XJ
2	N300179	1	HANDLE			No	XJ
3	330019-22	1	SCREW	M5.74x32		Yes	XJ
4	330045-17	7	SCREW	M5X30 METAL THD FORM		Yes	XJ
5	330019-32	6	SCREW			No	XJ
6	N736822	1	HANDLE SA			No	XJ
7	N300152	1	CAP			No	XJ
8	330045-14	1	SCREW			Yes	XJ
9	N466092	1	CONTROL MODULE SA			No	XJ
10	330019-12	1	SCREW			No	XJ
14	330045-45	10	SCREW			Yes	XJ
15	N473984	1	ARM		INCL. 31,41	No	XJ
16	150075-00	2	SCREW			No	XJ
30	N449835	1	GEARCASE SA			No	XJ
31	386780-00	1	BEARING			No	XJ
32	605094-00	1	WIPER			No	XJ
33	058698-00	1	SPRING			No	XJ
34	629444-00	1	SPINDLE LOCK			No	XJ
39	N771116	1	LED LIGHT			No	XJ
41	330003-64	1	BEARING		MUST BE REPLACED	No	XJ
42	N415903	1	ARMATURE SA			No	XJ
44	N333139	1	BAFFLE			No	XJ
45	N389143	2	SCREW			No	XJ
46	N436044	1	MAGNET			No	XJ
47	N412223	1	BRUSH HOLDER SA			No	XJ
49	N300071	1	HOUSING MOTOR			No	XJ
51	N300072	1	END CAP			No	XJ
52	330019-03	2	SCREW			No	XJ
800	283484-01	1	GREASE	32oz, EXXON CVJ		No	XJ